

NORGAS CONTROLS INC.

Regulation & Measurement

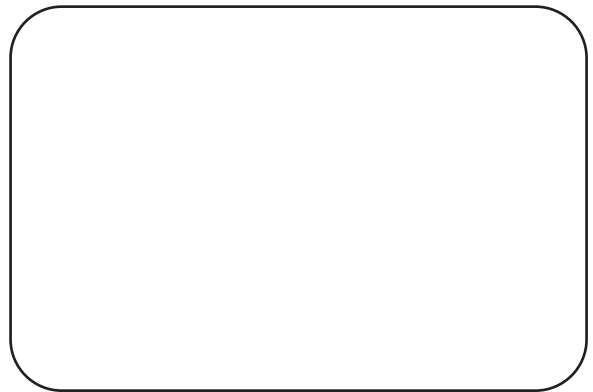

Distributed By



Spring Loaded Regulators

Master Distributor
for

Itron



www.norgascontrols.com

B42 Series Regulator

- Increased Safety ▶
- Long Service Life ▶
- Easy to Install ▶



Applications

Consistent pressure reduction of gas for typical domestic and light commercial applications.

Description

The B42R is a spring loaded self-operated regulator with internal relief. The B42R features a molded diaphragm, 6:1 lever ratio. The benefit is a lighter more compact unit that provides the power, capacity and relief performance of larger regulators.

Compact Size

While the model B42 is more compact than traditional regulators, it was also designed to meet customer expectations for safety and long field life. The B42 is designed to consolidate product usage for both residential and light commercial applications.

**Model B42 Series regulators
exceed all AGA/ANSI B109.4
& CSA 6-18 specifications**

Features

- Interchangeable aluminum orifice
- 12.6 sq in² of diaphragm area
- Molded deep convolution diaphragm with o-ring seal
- Plated steel diaphragm plate
- Stainless steel lever pin
- Plated steel 6:1 lever
- One piece molded Buna-N valve seat
- Die cast zinc valve stem
- Delrin[®] vent valve with Buna-N seat
- Spring loaded internal relief valve assembly
- Vent Size: 3/4" threaded (standard) with stainless steel screen, 1" also available.
- Fiberglass reinforced polyethylene seal cap with integral relief valve stop
- Field interchangeable adjustment spring
- CSA 6.18 Approved
- Measurement Canada Approved-G0108
- ANSI B109.4 Compliant

Operating Temperature Range:

-20°F to 150°F
-29°C to 65°C

Itron



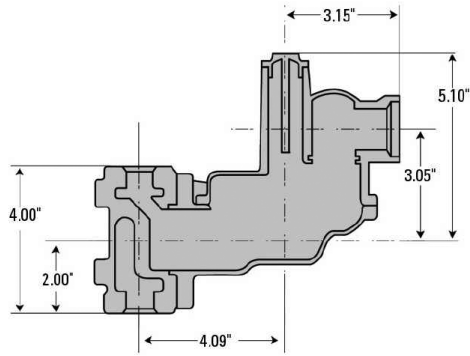

**Valve
Body Sizes***

Inlet	Outlet
1/2" x 1/2"	
3/4" x 3/4"	
3/4" x 1"	
1" x 1"	
1 1/4" x 1 1/4"	

* 90° Angle Bodies Available

Spring Ranges

Spring Color	Outlet Pressure Range
Dark Green	6" - 16" w.c.
Silver	12" - 28" w.c.
Yellow/Black	1 - 2 PSIG

**HP Version available
for 2 to 5 PSI delivery**

**Capacities in SCFH – Orifice Size
7" WC Set Point (1" Droop)**

Inlet Pressure PSIG	1/4"	3/8"	1/2 x 9/16"
2	250	425	700
5	500	825	1230
10	850	1300	1720
15	1200	1650	
20	1450	2000	
30	2000		

**Capacities in SCFH – Orifice Size
14" WC Set Point (2" Droop)**

Inlet Pressure PSIG	1/4"	3/8"	1/2 x 9/16"
2	300	450	860
5	550	740	1310
10	820	1130	1680
15	1070	1460	
20	1320	1800	
30	1750		

**Capacities in SCFH – Orifice Size
2 PSI Set Point (2% Droop)**

Inlet Pressure PSIG	1/4"	3/8"	1/2 x 9/16"
5	460	730	1085
10	850	1280	1710
15	1150	1600	
20	1420	2000	
30	1920		

Shaded Area=Orifice Pressure Exceeded

Maximum Capacities on inches w.c. outlet:

- 1-1/4" outlet connection - 2500 scfh
- 1" outlet connection - 1200 scfh
- 3/4" outlet connection - 600 scfh

B31 Series Regulator

Light Commercial and Industrial Regulator

- Smooth control at widely varying inlet pressures ▶
- Light weight ▶
- Easy to install ▶
- Rugged construction ▶
- Protection from shock damage ▶
- Unmatched overpressure protection with Internal Monitor plus Internal Relief (IMR) option ▶
- No special tools required for outlet pressure adjustment ▶

Applications

Use where inches of water column or pounds delivery is desired such as utility services, and small to medium sized furnaces and boilers.

The rapid response of the B31 is particularly well suited for applications where sudden on/off loads could cause shock problems.

B31R

The B31R is the internal relief valve (R) version of the B31 Series. The 3/4" internal relief valve provides exceptional relief capacity.



Features

- Field Interchangeable orifice
- 27 sq. in. diaphragm area
- Spring-loaded internal relief valve assembly
- Interchangeable adjustment spring
- Controlled breather orifice
- Wide range of NPT valve body sizes
- Vent Size: 3/4" threaded (standard) with stainless steel screen, 1" also available
- CSA 6.18 Approved
- Measurement Canada Approved - G0108
- ANSI B109.4 Compliant

Operating Temperature Range:

-20°F to 150°F
-29°C to 65°C

Itron



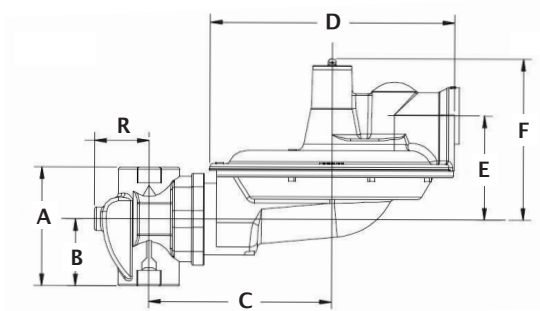

B31 Dimensions

Valve Body	3/4" & 1"	1-1/4"
A	3-3/4"	4"
B	2-1/8"	2-1/8"
C	5-13/16"	5-13/16"
D	7-13/16"	7-13/16"
E	3-1/4"	3-1/4"
F	4-7/8"	4-7/8"
R	2-1/4"	2-1/4"

Valve Body Sizes

Inlet	Outlet
3/4" x 3/4"	
1" x 1"	
1 1/4" x 1 1/4"	

Spring Ranges

Spring Color	Outlet Pressure Range
Gray	4" - 9" w.c.
Black	7" - 11" w.c.
Blue	8" - 12" w.c.
Silver	11" - 16" w.c.
HP Version	
Red/Gray	.5 - .9 PSI
Red/Blue	.75 - 1.1 PSI
Yellow	.9 - 1.4 PSI
Red	1.3 - 2 PSI
White	1.75 - 2.5 PSI

**Capacities in SCFH – Orifice Size
7" WC Set Point (1" Droop)**

Inlet Pressure PSIG	3/8"	1/2 x 9/16"
2	845	1200
5	1400	2200
10	2200	2500
20	2500	2500
30	2680	3000

**Capacities in SCFH – Orifice Size
14" WC Set Point (2" Droop)**

Inlet Pressure PSIG	3/8"	1/2 x 9/16"
2	475	630
5	800	1100
10	1180	1500
20	1400	1550
30	1550	1700

**Capacities in SCFH – Orifice Size
2 PSI Set Point – HP Version (2% Droop)**

Inlet Pressure PSIG	3/8"	1/2 x 9/16"
5	700	1225
10	1100	1440
20	1800	2400
30	2100	2500

Maximum Capacities on inches w.c. outlet:

- 1-1/4" outlet connection - 2500 scfh
- 1" outlet connection - 1200 scfh
- 3/4" outlet connection - 600 scfh

B34S Series Regulator

Medium Duty Commercial and Industrial Regulator

- Economical ▶
- Space-saving design ▶
- Protects equipment from shock damage ▶
- Commercial performance in a compact size ▶

Applications

Appropriate for many commercial and industrial uses such as gas engines, burners, furnaces, and boilers. The rapid response of the B34 S is particularly well-suited for mid-range applications where quick on/off loads cause shock problems.

Description

The B34 S is a spring-loaded self-operated regulator available with internal relief. It combines the B31 8" diaphragm case with the B34 valve assembly for an economical solution to mid-range commercial and industrial applications.

Among its attributes are an adjustable loading ring for controlled boost at high flows, precision breather opening to ensure proper stability under all conditions, and in the R model, a high capacity internal relief valve. All critical parts are either steel or aluminum, not plastic, to ensure reliability.

B34SR

The B34SR is the internal relief (R) version of the B34S Series regulator. The 1" internal relief valve provides exceptional relief capacity.



Features

- Interchangeable brass orifice
- Molded diaphragm consisting of Buna-N and nylon
- Upper diaphragm plate of plated steel
- Stainless steel lever pin
- Zinc with dichromate plated steel lever
- One piece molded Buna-N valve seat
- Alodined aluminum valve stem
- Delrin® vent valve with Buna-N seat
- Spring-loaded internal relief valve assembly
- Vent Size 1"
- Stainless steel vent screen
- Die cast aluminum seal cap
- Field interchangeable adjustment spring

Note:

Not for use on "Make-up Air Units" and other full modulating equipment. See B34R

Operating Temperature Range:

-20°F to 150°F
-29°C to 65°C

Itron

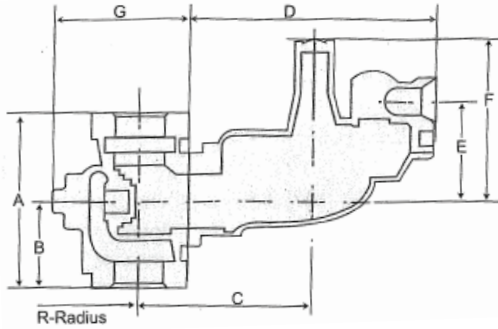

B34SR Dimensions

Valve Body	Screwed	Flanged
A	5-1/4"	10"
B	2-7/8"	5"
C	6"	-
D	7-13/16"	-
E	3-1/4"	-
F	4-7/8"	-
G	4-1/2"	5-1/2"
R	2-1/4"	3-1/4"

Valve Body Sizes

Inlet	Outlet
1 1/4" x 1 1/4"	
1 1/2" x 1 1/2"	
2" x 2"	
2" Flanged	
3" Flanged	

Spring Ranges

Spring Color	Outlet Pressure Range
Gray	4" - 8" w.c.
Black	6" - 9" w.c.
Blue	8" - 12" w.c.
Silver	11" - 17" w.c.
HP Version	
Red/Gray	.5 - .9 PSI
Red/Blue	.75 - 1.1 PSI
Yellow	1.2 - 1.5 PSI
Red	1.5 - 1.9 PSI
White	1.75 - 2.5 PSI

Capacities in SCFH – Orifice Size 7" WC Set Point (1" Droop)

Inlet Pressure PSIG	3/8" x 1/2"	1/2" x 5/8"	5/8" x 3/4"	7/8" x 1"
2	1080	1520	1830	2300
5	1960	3000	3820	5150
10	3280	5250	6600	7500
15	3980	6950	7500	
20	4625	7225		
25	5250	7500		

Capacities in SCFH – Orifice Size 14" WC Set Point (2" Droop)

Inlet Pressure PSIG	3/8" x 1/2"	1/2" x 5/8"	5/8" x 3/4"	7/8" x 1"
2	1010	1150	1500	1880
5	1740	2200	2940	4300
10	3000	4550	6000	7500
15	3850	7000	7500	
20	4475	7250		
25	5100	7500		

Capacities in SCFH – Orifice Size 2 PSI Set Point – HP Version (2% Droop)

Inlet Pressure PSIG	3/8" x 1/2"	1/2" x 5/8"	5/8" x 3/4"	7/8" x 1"
5	1200	1440	1690	2300
10	1920	2320	2760	4200
15	2700	2950	3780	
25	3850	4950		
35	4950			

Shaded Area=Orifice Pressure Exceeded

Maximum Capacities on inches w.c. outlet:

- 2" outlet connection - 10000 scfh
- 1-1/2" outlet connection - 7500 scfh
- 1-1/4" outlet connection - 2500 scfh

B34 Series Regulator

Commercial and Industrial Regulator

- Economical ▶
- Light weight ▶
- Protects equipment from shock damage ▶
- Large 12" diaphragm for better outlet pressure control ▶
- Unmatched overpressure protection with Internal Monitor plus Internal Relief (IMR) option ▶

Applications

Appropriate for many commercial and industrial uses such as gas engines, burners, furnaces, and boilers. The rapid response of the B34 is particularly well-suited for mid-range applications where quick on/off loads cause shock problems.

B34R

The B34R is the internal relief version of the B34 Series. This model features an adjustable loading ring for controlled boost at higher flows, a precision breather opening to ensure proper stability for all conditions, and a 1" internal relief valve.

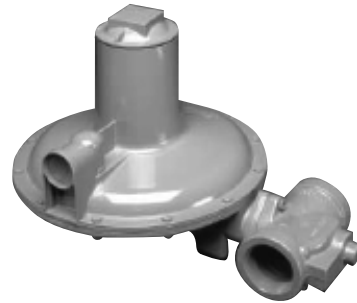

Features

- Interchangeable brass orifice
- 78 in² of diaphragm area
- Spring-loaded internal relief valve assembly
- Field interchangeable adjustment spring
- Controlled size breather orifice eliminates pulsation and provides normal actuation at low flows
- Wide range of valve body sizes including NPT and Flange connections
- Measurement Canada Approved - G0108

Operating Temperature Range:

-20°F to 150°F
-29°C to 65°C

Maximum Capacities on inches w.c. outlet:

2" outlet connection - 10000 scfh
1-1/2" outlet connection - 7500 scfh
1-1/4" outlet connection - 2500 scfh

Itron

Flanged Valve Body

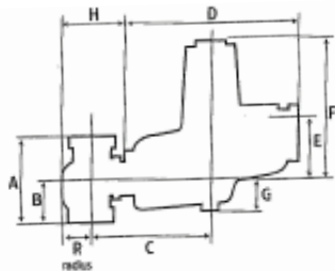
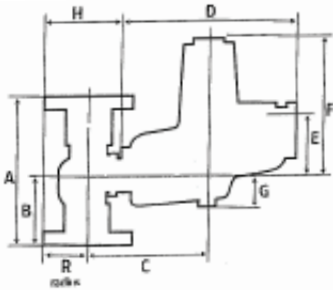

Screwed Valve Body

Valve Body Sizes

Inlet	Outlet
1 1/4" x 1 1/4"	
1 1/2" x 1 1/2"	
2" x 2"	
2" Flanged	
3" Flanged	

Spring Ranges

Spring Color	Outlet Pressure Range
Orange	3" - 5" W.C.
Brown	4" - 6.5" W.C.
Green	5" - 8" W.C.
Black	6.5" - 13" W.C.
Purple	9.1" - 20.8" W.C.
Blue	15" - 28" W.C.
Silver	1 - 2 PSI
Yellow	2 - 4.5 PSI
Red Nested	4 - 5.5 PSI
White Nested	4.8 - 7.3 PSI

**Capacities in SCFH – Orifice Size
7" WC Set Point (1" Droop)**

Inlet Pressure PSIG	3/8" x 1/2"	1/2" x 5/8"	5/8" x 3/4"	7/8" x 1"
2	1500	2000	3300	4700
5	2400	4000	5700	8000
10	3500	5700	9000	10000
20	5000	8500	10000	10000
30	6500	10000	10000	

**Capacities in SCFH – Orifice Size
14" WC Set Point (2" Droop)**

Inlet Pressure PSIG	3/8" x 1/2"	1/2" x 5/8"	5/8" x 3/4"	7/8" x 1"
2	1400	1900	2800	4400
5	2300	4000	5000	6500
10	3200	6000	7600	10000
20	5000	8500	10000	10000
30	6900	10000	10000	

**Capacities in SCFH – Orifice Size
2 PSI Set Point (2% Droop)**

Inlet Pressure PSIG	3/8" x 1/2"	1/2" x 5/8"	5/8" x 3/4"	7/8" x 1"
5	2000	3100	3600	6000
10	3000	5800	7000	12000
20	4800	9000	12000	19000
30	6500	11500	16000	21800

**Capacities in SCFH – Orifice Size
5 PSI Set Point (2% Droop)**

Inlet Pressure PSIG	3/8" x 1/2"	1/2" x 5/8"	5/8" x 3/4"	7/8" x 1"
10	1200	1550	2000	2500
20	2300	2850	3500	4500
30	2800	3500	4400	7200
50	4800	7000	7500	11500

Valve Body Type	Dimensions								
	A	B	C	D	E	F	G	H	R
1-1/4", 1-1/2" or 2" NPT	5-3/4"	2-7/8"	8-11/16"	12-3/4"	4-5/16"	10"	2-3/16"	4-1/2"	2-1/4"
2" Flanged	10"	5"	8-11/16"	12-3/4"	4-5/16"	10"	2-3/16"	5-1/2"	3-1/4"
3" Flanged	10"	5"	8-11/16"	12-3/4"	4-5/16"	10"	2-3/16"	5-1/2"	3-1/4"

B38 Series Regulator

Commercial and Industrial Regulator

- ▶ 2" relief vent provides exceptional internal relief performance; replaces the need for external relief valves
- ▶ Valve body takes up to 1-3/8" orifice for increased capacity
- ▶ Fast response protects equipment from shock damage
- ▶ Large 12" diaphragm for smooth outlet pressure control
- ▶ Unmatched overpressure protection with Internal Monitor plus Internal Relief (IMR) option
- ▶ No special tools required for outlet pressure adjustment

Applications

Appropriate for large capacity commercial and industrial uses where inches of water column or pounds delivery is desired such as utility services, gas engines, burner trains, furnaces, and boilers.

The rapid response of the B38 is particularly well suited for applications where sudden on/off loads could cause shock problems.

B38R

The B38R is the internal relief (R) version of the B38 Series. The large 2" internal relief valve provides exceptional relief capacity.



Features

- Interchangeable orifice
- 78 in² of diaphragm area
- Spring-loaded internal relief valve assembly
- Field interchangeable adjustment spring
- Controlled size breather orifice eliminates pulsation and provides normal actuation at low flows
- Wide range of valve body sizes including NPT and Flange connections

Operating Temperature Range:

-20°F to 150°F
-29°C to 65°C

Itron

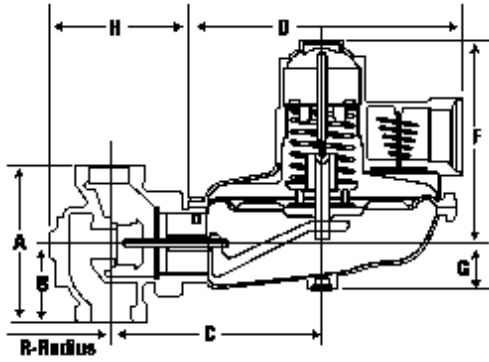

Valve Body Sizes

Inlet	Outlet
1-1/2" x 1-1/2"	
2" x 2"	
2" Flanged	
3" Flanged	

Spring Ranges

Spring Color	Outlet Pressure Range
Orange	3" - 4.5" W.C.
Brown	3.9" - 6" W.C.
Green	5" - 8" W.C.
Black	9.6" - 15" W.C.
Purple	13.5" - 22" W.C.
Blue	17.75" - 30" W.C.
Blue/White	27.4" W.C. - 1.6 PSI
Silver	1.4 - 2.5 PSI
Silver/Red	1.8 - 2.9 PSI
Yellow	2.52 - 4 PSI
Red Nested	1.96 - 6.7 PSI
White Nested	2.1 - 7.8 PSI

**Capacities in SCFH – Orifice Size
7" WC Set Point (1" Droop)**

Inlet Pressure PSIG	5/8"	1"	1 3/8"
2	2150	4100	5850
5	4300	8000	10800
10	6900	12800	17700
20	10150	13750	20000
30	12000		

**Capacities in SCFH – Orifice Size
14" WC Set Point (2" Droop)**

Inlet Pressure PSIG	5/8"	1"	1 3/8"
2	2100	3100	5000
5	3500	7000	9000
10	6300	10500	13500
20	10500	15500	20000
30	14000	20000	

**Capacities in SCFH – Orifice Size
2 PSI Set Point (2% Droop)**

Inlet Pressure PSIG	5/8"	1"	1 3/8"
5	2500	4450	6350
10	4800	8000	11500
20	8000	13000	18500
30	10500	17500	

**Capacities in SCFH – Orifice Size
5 PSI Set Point (2% Droop)**

Inlet Pressure PSIG	5/8"	1"	1 3/8"
10	2000	2500	4000
20	2700	4000	5200
30	3600	6200	
50	6000	9000	

Valve Body Type	Dimensions								
	A	B	C	D	E	F	G	H	R
1-1/2" or 2" NPT	7-1/2"	3-3/4"	10-5/8"	13"	5"	9-5/8"	2-3/16"	6-3/4"	3-3/8"
2" Flanged	10"	5"	10-5/8"	13"	5"	9-5/8"	2-3/16"	6-1/2"	3-15/16"
3" Flanged	10"	5"	10-5/8"	13"	5"	9-5/8"	2-3/16"	7-3/8"	4-3/16"

B36 Series Regulator

High Pressure Service Regulator

- ▶ Light weight, compact
- ▶ Internal relief
- ▶ Easy field servicing
- ▶ Controlled boost
- ▶ Ideal for suburban tap and industrial applications



Applications

The B36 is a pounds-to-pounds reducing regulator for inlet pressures up to 175 PSIG and outlet pressures from 1 to 60 PSIG. Designed for use in two stage reduction applications where required.

B36R

Relief Valve Characteristics

Internal relief is an exclusive feature in this type of regulator. Provides an added safety factor not found in other regulators of this type.

The lever assembly is zinc plated steel with built in safety stops for proper operation of the relief valve in event of mechanical failure of other parts.

The relief valve is separated from the diaphragm clamping and maintains a guided positive alignment with the "O" ring seat. Combines large throat opening, relief valve and vent area. Provides quick passage of gas to relief area and large relief flow. Vent is 3/4" N.P.T. with stainless steel screen and complete water drain when installed pointing downward.

Features

- Built-in internal relief valve
- Inlet pressures up to 175 PSIG
- Outlet pressure 1 to 60 PSIG
- Upper and lower diaphragm case are light weight die cast aluminum
- 16 different assembly positions

Operating Temperature Range:

- 20°F to 150°F
- 29°C to 65°C

Itron

Capacity Table at 10% Outlet -Pressure Change

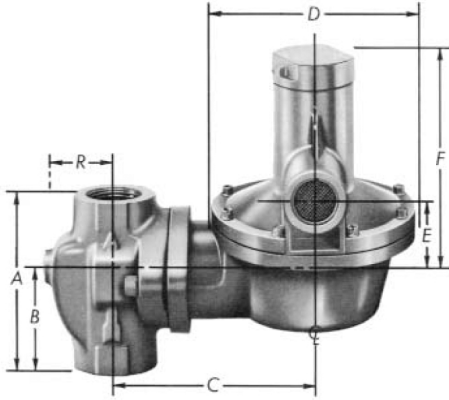

B36 Dimensions

Valve Body	3/4" & 1"	1-1/4"
A	3-3/4"	4"
B	2-1/8"	2-1/8"
C	4-7/8"	4-7/8"
D	4-7/8"	4-7/8"
E	2-5/8"	2-5/8"
F	5-1/2"	5-1/2"
R	2-1/4"	2-1/4"

Valve Body Sizes

Inlet	Outlet
3/4" x 3/4"	
1" x 1"	
1 1/4" x 1 1/4"	

Spring Ranges

Spring Color	Outlet Pressure Range
Brown	0.75 - 2.5
Green	1.5 - 10
Black	5 - 15
Blue	9 - 30
Silver	25 - 60

Inlet Pressure PSIG	Outlet Pressure PSIG & Spring	1/8" 10%	1/4" 10%
20	5 GR	375	625
	10 BLA	430	725
	15 BLU	325	600
40	5 GR	575	900
	10 BLA	660	1325
	15 BLU	700	1125
	20 BLU	750	1400
	25 BLU	700	1450
	30 SIL	475	600
60	5 GR	700	850
	10 BLA	750	1325
	15 BLU	900	1225
	20 BLU	1075	1625
	25 BLU	1075	1700
	30 SIL	500	1075
	40 SIL	675	1175
75	5 GR	875	1000
	10 BLA	1100	1600
	15 BLU	1050	1500
	20 BLU	1250	1700
	25 BLU	1300	2050
	30 SIL	775	1075
	40 SIL	825	1300
	60 SIL	875	1600
	60 SIL	875	1600
100	5 GR	1025	1300
	10 BLA	1500	1900
	15 BLU	1325	1850
	20 BLU	1550	2300
	25 BLU	1700	2600
	30 SIL	925	1450
	40 SIL	1075	1875
	60 SIL	1100	2150

Notes:

Maximum inlet pressure per orifice size:
175 PSIG 1/8" orifice
150 PSIG 1/4" orifice

Gas Relief Vents

Richards Gas Vents keep:

- Water ▶
- Insects ▶
- Debris ▶

out of your Gas Relief Piping!!

Features

- Non corrosive aluminum.
- 16 x 16 0.018 gauge screen.
- Made for use on all ReliefVent Piping.
- Screen designed to blow out in the event the screen becomes blocked.
- Available from 3/4" to 2" female connection.

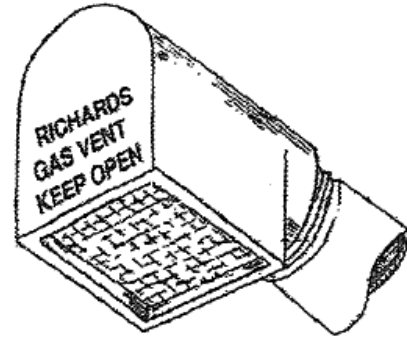

Test Plugs (Pete's Plugs)

- ▶ **Model 100 Pete's Plug**
- ▶ **Model 500 Gauge Adapter**

Take pressure and temperature readings quickly with line pressurized. Reduce the need for costly permanent installation of gauges on the line.

Features

- 1/4" NPT Brass Body and Cap
- Neoprene Valve Core
- 500 PSIG Maximum Pressure
- 200°F Maximum Temperature

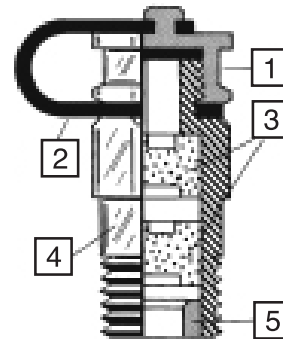

Cross section:

- 1 Cap and Gasket
- 2 Cap retaining strap
- 3 Two self closing valves with interaction to speed valve closure
- 4 Valve body
- 5 Valve retainer

General Conversions

Multiply	By	To Obtain
Acres	43560	Square Feet
Atmospheres	1.033	Kilograms per cm ²
Atmospheres	14.696	PSI
Barrels	5.614	Cubic Feet
Barrels	0.15898	Cubic Meters
Barrels	42	Gallons (U.S.)
Bar	100	Kilopascals
Bar	14.5	PSI
Bar	.987	Atmospheres
Boilen HP	34	Lb/Hr (steam)
Btu	252.0	Calories
Btu	1055.0	Joules
Centigrade (Degrees)	(°Cx9/5)+32	Fahrenheit (Degrees)
Centimeters	0.032808	Feet
Centimeters	0.3937	Inches
Centimeters	0.010936	Yards
Cubic Centimeters	0.06102	Cubic Inches
Cubic Centimeters	0.03381	Fluid Ounces
Cubic Feet	0.02832	Cubic Meters
Cubic Feet	7.480	Gallons
Cubic Feet	28.316	Liters
Cubic Feet per Min.	0.4719	Liters per Sec.
Cubic Feet per Min.	0.02832	Meter ³ per Min.
Cubic Feet Water	62.366	Pounds (AVDP)
Cubic Inches	16.387	Cubic Centimeters
Cubic Inches	0.01639	Liters
Cubic Meters	6.289	Barrels
Cubic Meters	35.3146	Cubic Feet
Cubic Meters	1.30795	Cubic Yards
Cubic Meters	264.172	Gallons
Cubic Meters per Hour	4.4028	Gallons per Min.
Cubic Meters/Day	1.47	Cubic Ft/Hr
Fahrenheit (Degrees)	(°F-32)x5/9	Centigrade (Degrees)
Feet	30.48	Centimeters
Feet	0.3048	Meters
Gallons	0.02381	Barrels
Gallons	0.003785	Cubic Meters
Gallons	231.0	Cubic Inches
Gallons	3.785	Liters
Gallons per Min.	34.296	Barrels per Day
Gallons per Min.	227.1	Liters per Hour
Gallons per Min.	0.0631	Liters per Sec.
Gallons (IMP)	1.201	Gallons
Gallons Water at 60°c	8.337	Pounds (AVDP) of Water
Grams	0.0353	Ounces
Grams per Cm. ³	0.0361	Pounds, per Cubic Inch
Grams per Cm. ³	0.01422	PSI
Horsepower	2545	BTU/Hr
Horsepower	0.7457	Kilowatts
Horsepower	745.7	Watts
Horsepower	550	Foot Pound per Sec.
Inches W.C.	.0361	PSI
Inches W.C.	0.0735	Inches Hg
Inches Hg	.4912	PSI
Inches Hg	1.1308	Feet Water

Multiply	By	To Obtain
Inches	2.54	Centimeters
Inches	0.0254	Meters
Joules	.738	Foot Pounds
Kilograms	35.2739	Ounces
Kilograms	2.20462	Pounds (AVDP)
Kilograms	0.001102	Short Tons
Kilograms per Meter ²	.001422	PSI
Kilograms per Cm ²	14.223	PSI
Kilometers	3280	Feet
Kilometers	0.6214	Miles (Statute)
Kilopascals	.145	PSI
Kilopascals	.010	Bar
Kilowatts	1.3405	Horsepower
Kilowatt hours	3412.0	Btu
Lb/Ft	1.488	Kg/meters
Lb/Ft ²	.016	g/m ²
Liters per Hr.	0.0044	Gallons per Min.
Liters	0.2642	Gallons
Liters	0.03531	Cubic Feet
Liters	61.025	Cubic Inches
Meters	3.2808	Feet
Meters	39.370	Inches
Meters	1.0936	Yards
Microns	3.94x10 ⁻⁵	Inches
Microns	.001	Millimeters
Miles (Statute)	5280	Feet
Miles (Statute)	1.6093	Kilometers
Millimeters	0.03937	Inches
Pascal	1.0	Newton/Meter ²
Ounce (AVDP)	28.35	Grams
Pounds (AVDP)	0.4536	Kilograms
Pounds Force	4.448	Newton
Pounds	16	Ounces
PPM (Volume)	385.1x10 ⁻⁶	Lb/Ft ³
PPM (Volume)	28.8	PPM (by weight)
PSI	70.31	Grams per Cm ²
PSI	2.036	Inches Hg
PSI	0.07031	Kilograms per Cm ²
PSI	6.895	Kilopascals (kPa)
PSI	27.7	Inches W.C.
Quarts (U.S.)	.946	Liters
SQ Centimeters	.0155	Square Inches
Square Feet	0.0929	Square Meters
Square Inches	6.4516	SQ Centimeters
Square Inches	645.16	SQ Millimeters
SQ Kilometers	.3861	Square Miles
Square Meters	10.7639	Square Feet
Square Meters	1.1959	Square Yards
Square Miles	640	Acres
SQ Millimeters	0.00155	Square Inches
Square Yards	0.8361	Square Meters
Tons (U.S. short)	2000	Lbs
Watts	0.00134	Horsepower
Yards	91.44	Centimeters
Yards	0.9144	Meters

Comparison Chart

Itron	Fisher	Sensus	Canadian/American
B42R	HSRL	043, 143-6	1213, CR4000
B31R	S102	143-6, 143-8	1813C
B34SR	S302	243-8	-
B34R	S202	243-12	1813
B38R	-	-	1813B

*** Note - This is a guide only**

Notes

Notes

Notes

Other products available from



.....
Other Regulators available
Pilot Operated & Direct Acting



.....
Regulators for Natural & Propane Gas
High Pressure Regulators up to 5000 PSI
Filter Regulators & Gauges



.....
Gas Appliance Regulators



.....
Ventless Gas Regulators



.....
Lubricated two way & three way Plug Valves
CSA/CGA Approved

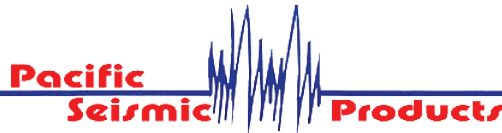

.....
Seismic "Earthquake" Valves
available from 3/4" to 8"



.....
Diaphragm, Rotary, Turbine,
Dattus and Accessories

Manufacturer standard warranty applies. For a copy please contact us.